



TT-, O- and M- SERIES
INSTALLATION, USAGE AND
MAINTENANCE INSTRUCTIONS



GENERAL CONSIDERATIONS

The FLAMES VLC burner is a professional cooking burner that can be run on propane, butane and natural gas (3rd and 2nd family) and has been designed to heat containers containing food.

This device does not require connection to a smoke evacuation device for the evacuation of the combustion by-products. For professional use, perfect for cooking paella or rice dishes, and to use with large pots or pans.

READ THE INSTRUCTIONS BEFORE THE USE.

Do not place the device on uninsulated surfaces. These must also be horizontal flat level surfaces.

Do not use the device with a type of gas for which it has not been manufactured.

The flames must not protrude from the base of the container.

Place the container on the appliance, resting it on the intended place. When heavier containers are to be placed on top of the device, we recommend the use of additional free-standing support systems.

The recommended container diameters (mm) for each model are:

GT-250 > Ø350

TT-380 > Ø480

TT-460 > Ø560

TT-500 > Ø600

TT-600 > Ø700

TT-700 > Ø800

TT-900 > Ø1.000

M-400 > Ø500

O-900 > Ø1.000

O-1200 > Ø1.300

INSTALLATION INSTRUCTIONS

The general gas installation must be carried out by a qualified technician according to the local regulations and must have a tap to cut off the gas, whenever it is needed.

When attaching the device to a copper installation, do not solder or weld next to the burner gas supply socket, as it could damage the safety valve.

Do not block the ventilation openings of the container. The protected pieces from the manufacturer mustn't be manipulated.

The appliance must be installed in a room properly ventilated to prevent the formation of concentration of substances harmful to health. During connection and commissioning of the equipment: Do not smoke, do not have near any possible ignition point.

Important: The device must always be placed on a non-flammable surface and never less than 500 mm away from any indoor-outdoor wall or any item made of a flammable material. It does not require any anchorage.

It is **forbidden** any modification of the appliance by any person not authorized by the manufacturer. The TT-900 burner must be used with legs measuring a minimum of 65 cm in height.

FORESEEABLE RISKS

This appliance has been thoroughly tested at the factory, so there is no risk foreseeable.

All the burners are equipped with a flame control device, with full control, which ensures the cutting of gas to the burners in the case of malfunction or shutdown of them.

For checking leaks in the connections of the appliance, use soapy water. **Never check with fire.**

This appliance must be away from flammable materials. Some parts may get very hot.

Any modification of the appliance must be carried out by qualified personnel authorized by the manufacturer.

Failure to do so would be dangerous.

Keep the children away.

Categories, gases and pressures. TT- and GT- Series.

Country	Category	2H G-20 (mbar)	2E G-20 (mbar)	2E+ G-20+G-25 (mbar)	3B/P G-30/G-31 (mbar)	3+ G-30+G-31 (mbar)	3P G-31 (mbar)
AT Austria	II _{2H3P}	20	-	-	-	-	50
BE Belgium	II _{2E3+} *II _{2E+3P}	-	-	20 - 25	-	28 - 30/37	50
BG Bulgaria	II _{2H3+}	20	-	-	-	28 - 30/37	-
CH Switzerland	II _{2H3+} *II _{2H3P}	20	-	-	-	28 - 30/37	50
CY Cyprus	II _{2H3B/P} *II _{2H3+}	20	-	-	30	28 - 30/37	-
CZ Czech Republic	II _{2H3B/P} *II _{2H3+} *II _{2H3P}	20	-	-	30	28 - 30/37	50
DE Germany	I _{2E} *I _{3P}	-	20	-	-	-	50
DK Denmark	II _{2H3B/P}	20	-	-	30	-	-
EE Estonia	II _{2H3B/P}	20	-	-	30	-	-
ES Spain	II _{2H3+} *II _{2H3P}	20	-	-	-	28 - 30/37	50
FI Finland	II _{2H3B/P}	20	-	-	30	-	-
FR France	II _{2E+3+} *II _{2E+3P}	-	-	20 - 25	-	28 - 30/37	50
GB United Kingdom	II _{2H3+} *II _{2H3P}	20	-	-	-	28 - 30/37	50
GR Greece	II _{2H3+}	20	-	-	-	28 - 30/37	-
HR Croatia	II _{2H3B/P}	20	-	-	30	-	-
HU Hungary	II _{2H3B/P}	20	-	-	30	-	-
IE Ireland	II _{2H3+}	20	-	-	-	28 - 30/37	-
IS Iceland	II _{2H3+} *II _{2H3P}	20	-	-	-	28 - 30/37	50
IT Italy	II _{2H3B/P} *II _{2H3+}	20	-	-	30	28 - 30/37	-
LT Lithuania	II _{2H3B/P} *II _{2H3+}	20	-	-	30	28 - 30/37	-
LU Luxembourg	I _{2H}	20	-	-	-	-	-
LV Latvia	I _{2H}	20	-	-	-	-	-
MK Macedonia	II _{2H3+}	20	-	-	-	28 - 30/37	-
MT Malta	II _{2H3B/P} *II _{2H3+}	20	-	-	30	28 - 30/37	-
NL Netherlands	II _{2E3B/P} *I _{2P}	-	20	-	30	-	50
NO Norway	II _{2H3B/P}	20	-	-	30	-	-
PL Poland	I _{2E}	-	20	-	-	-	-
PT Portugal	II _{2H3+}	20	-	-	-	28 - 30/37	-
RO Romania	II _{2H3B/P}	20	-	-	30	-	-
SE Sweden	II _{2H3B/P}	20	-	-	30	-	-
SI Slovenia	II _{2H3B/P} *II _{2H3+}	20	-	-	30	28 - 30/37	-
SK Slovakia	II _{2H3B/P} *II _{2H3+} *II _{2H3P}	20	-	-	30	28 - 30/37	50
TR Turkey	II _{2H3+}	20	-	-	-	30/37	-

Categories, gases and pressures. O- and M- Series.

Country	Category	2H G-20 (mbar)	2E G-20 (mbar)	2E+ G-20+G-25 (mbar)	3P G-31 (mbar)
AT	Austria	II _{2H+3P}	20	-	50
BE	Belgium	II _{2E+3P}	-	20 - 25	50
BG	Bulgaria	I _{2H}	20	-	-
CH	Switzerland	II _{2H+3P}	20	-	50
CY	Cyprus	I _{2H}	20	-	-
CZ	Czech Republic	II _{2H+3P}	20	-	50
DE	Germany	I _{2E} •I _{3P}	-	20	50
DK	Denmark	I _{2H}	20	-	-
EE	Estonia	I _{2H}	20	-	-
ES	Spain	II _{2H+3P}	20	-	50
FI	Finland	I _{2H}	20	-	-
FR	France	II _{2E+3P}	-	20 - 25	50
GB	United Kingdom	II _{2H+3P}	20	-	50
GR	Greece	I _{2H}	20	-	-
HR	Croatia	I _{2H}	20	-	-
HU	Hungary	-	-	-	-
IE	Ireland	I _{2H}	20	-	-
IS	Iceland	II _{2H+3P}	20	-	50
IT	Italy	I _{2H}	20	-	-
LT	Lithuania	I _{2H}	20	-	-
LU	Luxembourg	I _{2H}	20	-	-
LV	Latvia	I _{2H}	20	-	-
MK	Macedonia	I _{2H}	20	-	-
MT	Malta	I _{2H}	20	-	-
NL	Netherlands	I _{2E} •I _{3P}	-	20	50
NO	Norway	I _{2H}	20	-	-
PL	Poland	I _{2E}	-	20	-
PT	Portugal	I _{2H}	20	-	-
RO	Romania	I _{2H}	20	-	-
SE	Sweden	I _{2H}	20	-	-
SI	Slovenia	I _{2H}	20	-	-
SK	Slovakia	II _{2H+3P}	20	-	50
TR	Turkey	I _{2H}	20	-	-

TT- and GT- SERIES

Consumption and performance of the main burners.

		1 - RING MODELS		2 - RING MODELS					
		GT-250		TT-380			TT-460		
		Ring Ø250 mm.		Ring Ø180 mm.	Ring Ø380 mm.	Pilot	Ring Ø250 mm.	Ring Ø460 mm.	Pilot
Nominal energy consumption. Heat input over LCV.	G20 (20 mbar) kW	9,50		4,87	10,66	0,24	7,69	11,36	0,24
	G30 (29 mbar) kW	7,00		3,81	8,31	0,19	5,36	8,68	0,16
	G31 (37 mbar) kW	11,20		5,28	11,89	0,23	7,85	12,73	0,21

		2 - RING MODELS			3 - RING MODELS			
		TT-500			TT-600			
		Ring Ø300 mm.	Ring Ø500 mm.	Pilot	Ring Ø180 mm.	Ring Ø380 mm.	Ring Ø600 mm.	Pilot
Nominal energy consumption. Heat input over LCV.	G20 (20 mbar) kW	7,77	11,54	0,23	4,64	11,37	13,89	0,30
	G30 (29 mbar) kW	6,68	8,43	0,18	3,93	8,55	8,93	0,32
	G31 (37 mbar) kW	7,69	12,24	0,22	5,30	11,39	15,57	0,34

		3 - RING MODELS				4 - RING MODELS			
		TT-700				TT-900			
		Ring Ø300 mm.	Ring Ø500 mm.	Ring Ø700 mm.	Pilot	Ring Ø300 + 500 mm.	Ring Ø700 mm.	Ring Ø900 mm.	Pilot
Nominal energy consumption. Heat input over LCV.	G20 (20 mbar) kW	8,17	11,20	12,53	0,30	13,87	14,22	13,94	0,43
	G30 (29 mbar) kW	6,92	8,79	10,41	0,29	12,75	10,61	12,62	0,40
	G31 (37 mbar) kW	8,71	9,70	12,96	0,33	15,77	12,29	15,89	0,45

TT- and GT- SERIES

Consumption of the appliances.

			1 - RING MODELS	2 - RING MODELS			3 - RING MODELS		4 - RING MODELS
			GT-250	TT-380	TT-460	TT-500	TT-600	TT-700	TT-900
Nominal energy consumption. Heat input over LCV.	G20 [20 mbar]	kW	9,50	15,53	19,05	19,31	29,90	31,90	42,03
	G30 [29 mbar]	kW	7,00	12,12	14,04	15,11	21,41	26,12	35,98
	G31 [37 mbar]	kW	11,20	17,17	20,58	19,93	32,26	31,37	43,95
Nominal consumption	G20 [20 mbar]	Nm ³ /h	1,01	1,642	2,014	3,160	2,041	3,372	4,443
	G31 [29 mbar]	kg/h	0,55	0,955	1,106	1,687	1,191	2,058	2,835
	G31 [37 mbar]	kg/h	-	0,941	1,090	1,661	1,173	2,027	2,792
	G31 [50 mbar]	kg/h	0,87	1,332	1,597	2,503	1,547	2,434	3,411

Air/gas ratio required for combustion.

Ensure correct supply of air/gas ratio following table recommendations.

GAS	AIR/GAS RATIO
G20	13,38 m ³ air/m ³ gas
G30	12,00 m ³ air/kg gas
G31	12,17 m ³ air/kg gas

O- and M- SERIES

Consumption and performance of the burner elements.

Consumption of the burner elements per model.

MODELS		M-400/16	O-900/31		O-1200/51		
			Ring Ø600 mm.	Ring Ø900 mm.	Ring Ø600 mm.	Ring Ø900 mm.	Ring Ø1200 mm.
Nominal energy consumption.Heat input over LCV. kW		31,00	31,00	29,10	31,00	29,10	37,00
Nominal consumption	G20 [20 mbar]	m ³ /h	3,28	3,28	3,08	3,28	3,91
	G20 + G25 (20/25 mbar)	m ³ /h	3,28	3,28	3,08	3,28	3,91
	G31 [50 mbar]	kg/h	2,41	2,41	2,26	2,41	2,87

Consumption of the appliances.

MODELS		M-400/16	O-900/31	O-1200/51
Nominal energy consumption.Heat input over LCV. kW		31,00	60,10	97,10
Nominal consumption	G20 [20 mbar]	m ³ /h	3,28	6,36
	G20 + G25 (20/25 mbar)	m ³ /h	3,28	6,36
	G31 [50 mbar]	kg/h	2,41	4,67

Air/gas ratio required for combustion.

Ensure correct supply of air/gas ratio following table recommendations.

GAS	AIR/GAS RATIO
G20	13,38 m ³ air/m ³ gas
G31	12,17 m ³ air/kg gas

GAS CONNECTION

Before turning on the cooker it is necessary to make sure there isn't any flame around and that **all the knobs are in a closed position**.

The device is supplied with a nozzle turned on the manifold itself with the standardised characteristics for each gas and country or with a 1/2" Ø threaded gas connection according to ISO 7-1, with the end prepared for the insertion of a sealing gasket.

The gas connections can be made with either rigid or flexible pipes.

In the case they are made with a rigid pipe, a gas trap must be installed as close to the appliance as possible. If flexible piping is used, it must be of a regulation type, duly approved.

The flexible pipe will be replaced when national conditions require it.

The flexible piping shall be approved and within the date of validity. Its length shall be less than 0,80 m when joined to a rigid pipe and less than 1,50 m when connected to a L.P.G. bottle.

TYPE OF REGULATOR

If the appliance is supplied from a bottle of L.P.G., **propane or butane**, a head pressure gas will be placed on the bottle (approved by the supplier of the bottle), with output pressure already adjusted to the pressure of consumption, up to 28/30 mbar, 37 mbar or 50 mbar. **THE USE OF HIGH-PRESSURE REGULATORS (VARIABLE OR FREE-FLOW) IS PROHIBITED.**

In case that it is approved for 50 mbar, the regulator should be for 50 mbar.
Burners of O- and M- Series must only be used with 50 mbar regulators.

When the appliance is connected to a **fixed mains gas (natural gas or L.P.G.)** and its pressure is not pre-set, a regulator calibrated to the pressure gas output corresponding to the injector of the apparatus will be inserted (see Table "categories, gases and pressures"), caring that the expected flow for the regulator exceeds the nominal consumption of the appliance.

USE AND MAINTENANCE INSTRUCTIONS

This appliance must be away from flammable materials while being used. Do not move the device while working. After use, close the external gas stopcock of the device or the stopcock on the cylinder regulator (L.P.G. gas).

Do not twist the flexible pipe while installing it or while using the appliance.

When replacing the gas container, the appliance should be away from flammable materials.

Wear protective gloves when handling hot elements.

Parts protected by the manufacturer must not be manipulated by the user. This device is intended for professional use and must be operated by professional staff with adequate training.

GT SERIES IGNITION

1. Verify that the knob is in the off position.
2. Open the gas supply valve, and if using a gas bottle, the regulator tap.
3. Push the thermocouple valve button. Keep pressed.
4. Press the burner knob slightly and turn 90° left as you place a flame source near the gas exit slots.
5. Once the burner is lit, and after a few seconds, release the thermocouple valve button.
6. The knob can now be turned at will between the maximum and minimum positions to achieve the desired gas consumption as explained by the icons below:

Switch-off position.

Pictured by the dot icon. ●

Switch on position. Flow rate and rotation direction.

Pictured by the flame icon.

Maximum: two flames, 90° left angle. 

Minimum: one flame, 160° left angle. 



GT SERIES TURN-OFF

1. Place all ring control knobs in the off position (●).
2. Close the installation gas supply valve or, if using a gas bottle, the regulator tap.

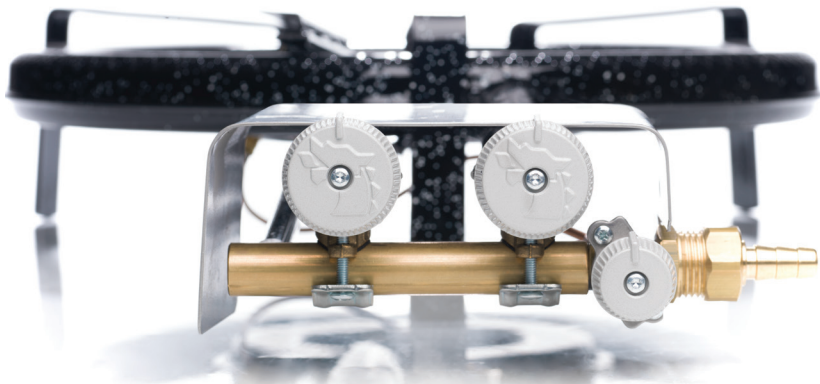

TT SERIES IGNITION

1. Verify that all control knobs are in the off position.
2. Open the gas supply valve, and if using a gas bottle, the regulator tap.
3. Ignition of the pilot burner rod (connecting all rings).
 - a. Press the thermocouple valve knob and turn 90° left.
 - b. Turn the knob to the on position (★), and press it to allow the gas to flow into the connecting pilot light rod while placing a flame source near it.
 - c. Keep the knob pressed for a few seconds until the thermocouple warms up and then release it. The connecting pilot light rod will remain on.

Off position.

Pictured by the dot icon. ●



Thermocouple valve knob for 2 ring burners.

On position.

Pictured by the star icon. ★

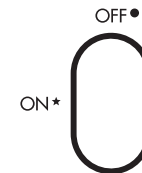

Thermocouple valve knob for 3 and 4 ring burners.

4. Ignition of the different rings.

Press lightly and turn the knob of the desired ring 90° to the left. Once the burner has been switched on, it is possible to switch between the maximum and minimum positions to achieve the desired consumption, as explained by the icons below:

Switch-off position.

Pictured by the dot icon. ●

Switch on position. Flow rate and rotation direction.

Pictured by the flame icon.

Maximum: two flames, 90° left angle.

Minimum: one flame, 160° left angle.



TT SERIES TURN-OFF

1. Place all ring control knobs in the off position (●).
2. Place the thermocouple valve knob in the off position (●).
3. Close the installation gas supply valve or, if using a gas bottle, the regulator tap.

O- and M- SERIES IGNITION

1. Open the stopcock on the gas line; in the case of using a bottle, the stopcock on the regulator.
2. Open the tap of the appliance or the tap of the ring that you want to turn on (see opened tap).
3. Press the button of the safety valve (see safety valve control button) so gas will flow to the burner.
4. Apply a flame to the corresponding burner and the gas will ignite, heating the thermocouple and allowing the safety valve button to be released after a few seconds. The gas flow will be maintained.

The tap handle is closed when it is in perpendicular position with the pipe, and the command is open when it is in parallel position with the pipe.

To achieve maximum flow, the tap should be turned counterclockwise.

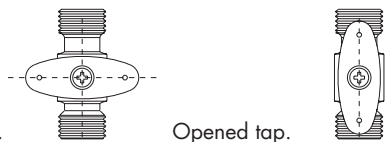

Safety valve control button.

The start button of the thermocouple is on the safety valve.

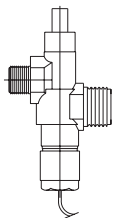

O- and M- SERIES TURN-OFF

1. Place the gas tap control in a position perpendicular to the pipe.
2. Close the external gas tap on the appliance or the tap on the cylinder (L.P.G. gas).

CONSERVATION AND MAINTENANCE

The gas valve is the only piece subject to replacement. If it needs to be replaced, this can only be carried out by the manufacturer or qualified personnel authorized by the manufacturer.

Check the expiry date of the flexible hose (printed on it) and replace it if necessary.

The appliance must be cleaned when it is cold with a cloth dampened in soapy water, then rinsed and dried (avoid getting water in the burners). Do not use caustic soda, hydrochloric acid or drill bits that could change the size of the holes.

Any operation other than cleaning the appliance must be carried out by qualified personnel authorized by the manufacturer, except for the replacement of the flexible pipe, which can be done by the user in accordance with the regulations of each country.

If there is a gas leak, close the gas tap on bottle or the one that is on the gas line.

Use soapy water to find the leak, never use fire.

These appliances require periodic cleaning of its functioning parts in order to avoid obstructions.

If the equipment is not used for a long time, wipe the steel surfaces with a cloth soaked in Vaseline to form a protective film.

Clean the burners and slots regularly to remove any scales that may form on them.

Care must be taken to ensure that the primary air inlet orifice is always clean and clear by wiping it with a cloth or similar.

The gas injector hole, in case of obstruction, shall be cleaned by blowing or by a stream of pressurized air, never introducing solids that may damage or change the diameter of the orifice.

VALVE LUBRICATION

Given the harsh working conditions to which these devices are often subject, regular valve lubrication is recommended by authorised personnel.

1. Close the general gas stopcock, making sure there are no sources of fire in the vicinity of the device.
2. Loosen screws A and B to remove the cone from the valve and clean away any dried grease.
3. Apply NONTROP-RB-3 DIN (Klüber Lubrication, Germany) or similar to the cone. Excessive grease will obstruct the passage of gas.
4. Reassemble the valve, checking for gas leaks.

ADAPTATION TO OTHER TYPE OF GASES

This adaptation must be carried out by the manufacturer or qualified staff authorized by the former. Both for the change of the gas and repairs should always use original manufacturer parts. When the appliance is adapted to a different type of gas for which it was prepared, in the supply of parts intended to adapt to another type of gas or other pressure, a sticker should be included for incorporation to the device. This label should have registered the nature and pressure of gas for which the device has been modified. To change from one type of gas to another, replace the injector with that corresponding to the gas to be used and regulate the primary air intake in accordance with the positions indicated for each gas type.

Injector Ø in mm.

TT- and GT- SERIES

1 - RING MODELS

FAMILY	GT-250
SECOND	
GROUP H (20 mbar)	2,85
GROUP E (20 mbar)	2,85
GROUP E+ (20/25 mbar)	2,85
THIRD	
GROUP B/P (29 mbar)	1,35
GROUP 3+ (29/37 mbar)	1,35
GROUP P (50 mbar)	1,65

2 - RING MODELS

FAMILY	TT-380			TT-460			TT-500		
	Ring Ø180 mm.	Ring Ø380 mm.	Pilot	Ring Ø250 mm.	Ring Ø460 mm.	Pilot	Ring Ø300 mm.	Ring Ø500 mm.	Pilot
SECOND									
GROUP H (20 mbar)	1,65	2,65	0,35	2,20	2,85	0,35	2,15	2,85	0,35
GROUP E (20 mbar)	1,65	2,65	0,35	2,20	2,85	0,35	2,15	2,85	0,35
GROUP E+ (20/25 mbar)	1,65	2,65	0,35	2,20	2,85	0,35	2,15	2,85	0,35
THIRD									
GROUP B/P (29 mbar)	1,00	1,50	0,22	1,20	1,55	0,22	1,35	1,55	0,22
GROUP 3+ (29/37 mbar)	1,00	1,50	0,22	1,20	1,55	0,22	1,35	1,55	0,22
GROUP P (50 mbar)	1,10	1,65	0,22	1,35	1,75	0,22	1,40	1,75	0,22

Note on primary air regulation.

The primary air regulation is to be fully-opened for all models and gases, with the exception of the following: Model TT-500 for group P (50 mbar) with an opening of 12 mm for the outer ring and 7 mm for the inner ring. Model TT-900 for group P (50 mbar) with an opening for the inner ring of 12 mm.

TT- and GT- SERIES

3 - RING MODELS

FAMILY	TT-600				TT-700			
	Ring Ø180 mm.	Ring Ø380 mm.	Ring Ø600 mm.	Pilot	Ring Ø300 mm.	Ring Ø500 mm.	Ring Ø700 mm.	Pilot
SECOND								
GROUP H (20 mbar)	1,65	2,65	3,00	0,42	2,20	2,65	2,85	0,42
GROUP E (20 mbar)	1,65	2,65	3,00	0,42	2,20	2,65	2,85	0,42
GROUP E+ (20/25 mbar)	1,65	2,65	3,00	0,42	2,20	2,65	2,85	0,42
THIRD								
GROUP B/P (29 mbar)	1,00	1,50	1,55	0,27	1,35	1,50	1,70	0,27
GROUP 3+ (29/37 mbar)	1,00	1,50	1,55	0,27	1,35	1,50	1,70	0,27
GROUP P (50 mbar)	1,10	1,65	1,90	0,27	1,45	1,55	1,75	0,27

4 - RING MODELS

FAMILY	TT-900			
	Ring Ø300 + 500 mm.	Ring 700 mm.	Ring 900 mm.	Pilot
SECOND				
GROUP H (20 mbar)	3,20	3,00	3,20	0,42
GROUP E (20 mbar)	3,20	3,00	3,20	0,42
GROUP E+ (20/25 mbar)	3,20	3,00	3,20	0,42
THIRD				
GROUP B/P (29 mbar)	1,80	1,70	1,80	0,27
GROUP 3+ (29/37 mbar)	1,80	1,70	1,80	0,27
GROUP P (50 mbar)	1,90	1,75	1,90	0,27

O- and M- SERIES

FAMILY	M-400/16	O-900/31		O-1200/51	
	A-200 Unitary element	A-200 Unitary element	P-470 Flame spreader burner element	A-200 Unitary element	P-620 Flame spreader burner element
SECOND					
GROUP H (20 mbar)	1,20	1,20	1,20	1,20	1,40
GROUP E (20 mbar)	1,20	1,20	1,20	1,20	1,40
GROUP E+ (20/25 mbar)	1,20	1,20	1,20	1,20	1,40
THIRD					
GROUP P (50 mbar)	0,70	0,70	0,70	0,70	1,00

REVISIONS

TT- and GT- SERIES

This appliance should be checked **every year**. If there is any problem, it is advisable to revise the appliance by a qualified technician.

Maintenance of the device must be undertaken by a fitter authorised by the manufacturer or by the gas company.

A thorough revision of the device is recommended at least every year. The following must be checked during the revision:

The airtightness of the gas circuit, replacing gaskets if necessary.

The operation of the ignition system and flame control thermocouple.

Pay special attention to the expiration date of the flexible pipe and replace it if necessary.

The valves must be lubricated by authorized staff.

O- and M- SERIES

This appliance should be checked **every three months**. The tightness of the gas line of the appliance will be checked by spraying gas tubes with soapy water. If there is any problem, it is advisable to revise the appliance by a qualified technician.

RISK PREVENTION

RISK

PREVENTION MEASURES

Accident caused by an inadequate use.

Use only for cooking of foodstuff in appropriate containers.

Accident caused by the user's lack of proper handling knowledge.

Use only by personnel trained to handle the device.

Accident caused by an incorrect use of the device.

Use the device following given instructions and paying close attention to stated warnings.

Collapse of the support caused by excess weight.

Use free-standing supports when placing heavy cooking containers.

Container overturning due to inadequate size.

Use only containers of recommended size (in the "general considerations" section).

Burning of nearby flammable surfaces.

Do not place the device on uninsulated surfaces. When in use, place the device away from any flammable materials.

Burns caused by contact with hot device elements.

Use protective gloves when handling hot elements. The knobs are protected by a protective case and placed at a reasonable distance from the burners to prevent their overheating.

Unpleasant smells caused by the burning of residue from previous uses.

Clean the burner rings after each use.

Malfunctioning of the safety valve due to a faulty coil.

Do not weld or solder near the burner gas supply connection to copper installations.

Malfunctioning of the safety valve button.

Contact the manufacturer's authorized personnel to solve the incident.

RISK PREVENTION

RISK	PREVENTION MEASURES
Blast in the venturi due to blockage of gas outlet slots.	Clean the burner rings after each use.
Blast in the venturi due to alterations of gas outlet slots due to incorrect cleaning.	Cleaning of the burner rings must be done with a cloth soaked in soapy water. Never use caustic soda lye, hydrochloric or muriatic acid, or drill the gas slots with bits which could alter their size.
Blast in the venturi due to incorrect gas supply pressure.	Always use a pressure regulator gauge adjusted to the pressure recommended in the specifications plate of the device.
Flame blowout or extinction due to incorrect pressure of gas supply line.	Always use a pressure regulator gauge adjusted to the pressure recommended in the specifications plate of the device.
Blast caused by gas accumulation after flame blowout.	The user must pay attention at all times, and verify that taps are in the "off" position in the absence of flame. Turn the device off following the instructions given in the manual, by manipulating valves or taps, and never by blowing out the flame or by closing the pressure regulator .
Incorrect performance due to modification of the device.	It is forbidden to make any alteration of the device by anyone other than the manufacturer.
A gas leak due to blows, or incorrect maintenance and use of the device.	Possible leaks should be located using soapy water, never use a flame source. If a leak is found, close the shut-off valve of the gas bottle regulator, or the gas supply valve.

EU COMPLIANCE STATEMENT

Optimgas S.L declares that, under its own responsibility, the appliances described in this manual GT-250, TT-380, TT-460, TT-500, TT-600, TT-700, TT-900, M-400/16, O-900/31 and O-1200/51 fulfil the requirements established by the UE in the (UE) 2016/426 alignment rule regarding **gas fuel burning appliances**, and by UNE EN 437, UNE EN 203-1 and UNE EN 203-2-1 harmonized regulations. This certification is guaranteed by the technical documentation held by the company; any appliance alteration carried out without our consent will cancel the validity of this warranty. The informed agency CERTIGAZ 1312 has carried out the required inspections of the appliances and has issued the EU Examination Certificate with the following PIN numbers:

- Models TT-380, TT-460 and TT-600: 1312BQ4455, rév. 4, date of issue 02/11/2022.
- Model GT-250: 1312BS5089, rév. 2, date of issue 02/11/2022.
- Models TT-500, TT-700 and TT-900: 1312CQ6070, rév. 2, date of issue 02/11/2022.
- Model M-400/16: 1312BV5449, rév. 2, date of issue 02/11/2022.
- Models O-900/31 and O-1200/51: 1312BV5450, rév. 2, date of issue 02/11/2022.

And issues a Certificate of Conformity with the type on an annual basis, with No. C.I.0213.

Signed in Alginet on 01/05/2026

Optimgas S.L.

Pol. Industrial Sur - Sector P.P.V.-2; parcela nº 29
46230 Alginet, València



D. Francisco Beltrán Segarra
Optimgas. L. General Manager



MAIN PARTS

TT SERIES

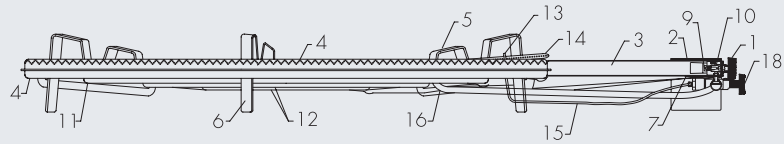
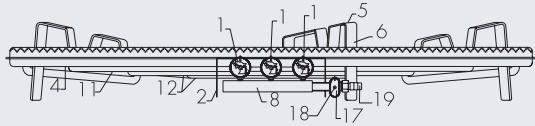

- 1- Gas valve control
- 2- Valve protection plate
- 3- Venturi tube Ø28 mm
- 4/11/12- Burner
- 5- Vessel support
- 6- Support legs
- 7- Primary air regulator
- 8- Gas train
- 9- Injector
- 10- Gas valve
- 13- Thermocouple
- 14- Ignition burner (pilot)
- 15- Thermocouple cable
- 16- Pilot tube Ø10 mm
- 17- Safety valve
- 18- Safety valve ignition button
- 19- Connection nipple

GT-250

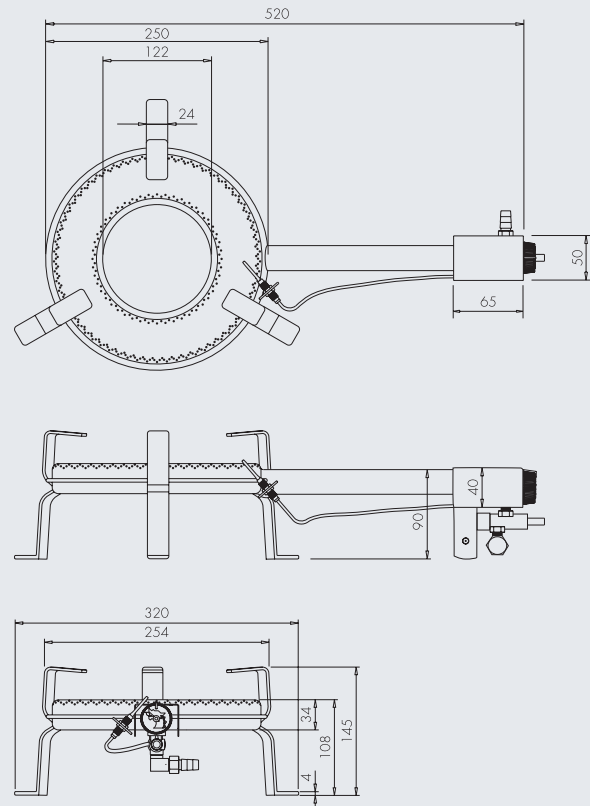

TT-380

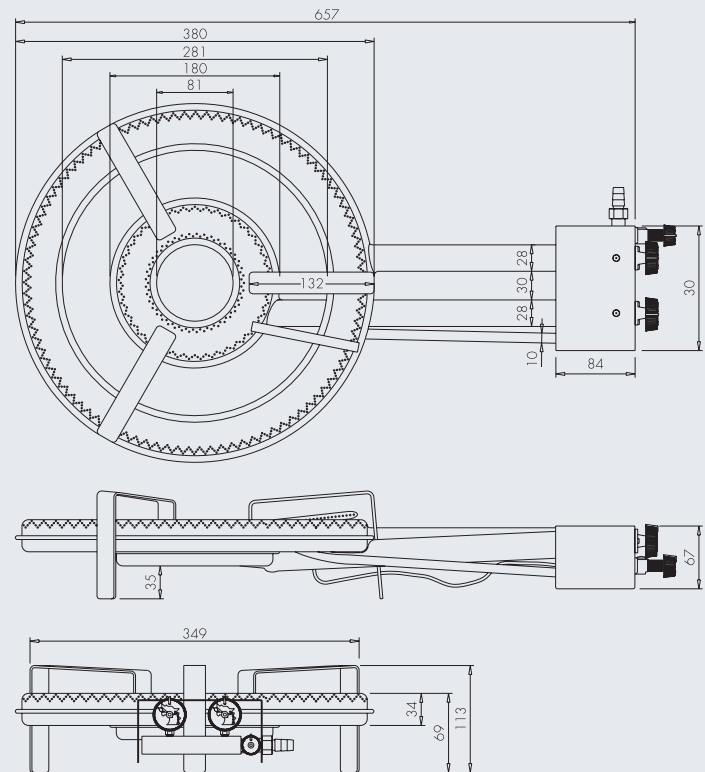

TT-460

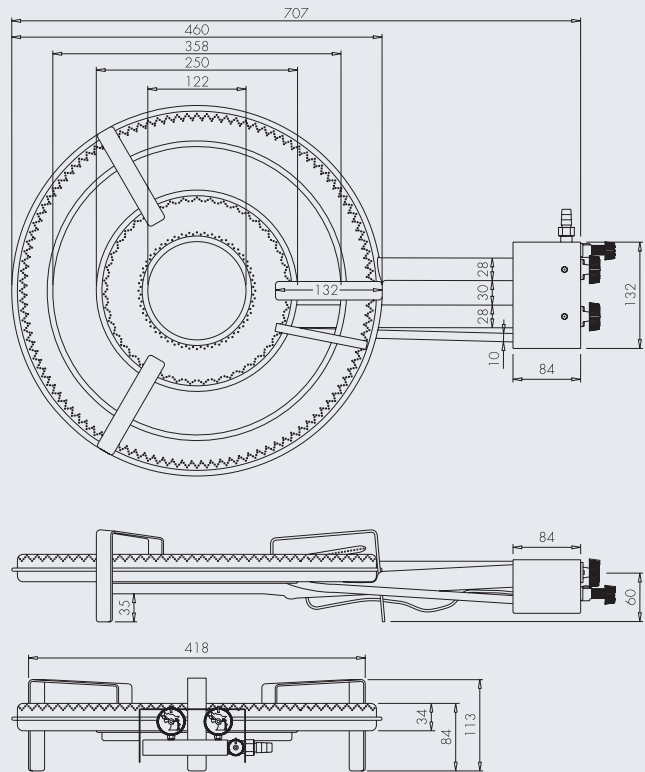

TT-500

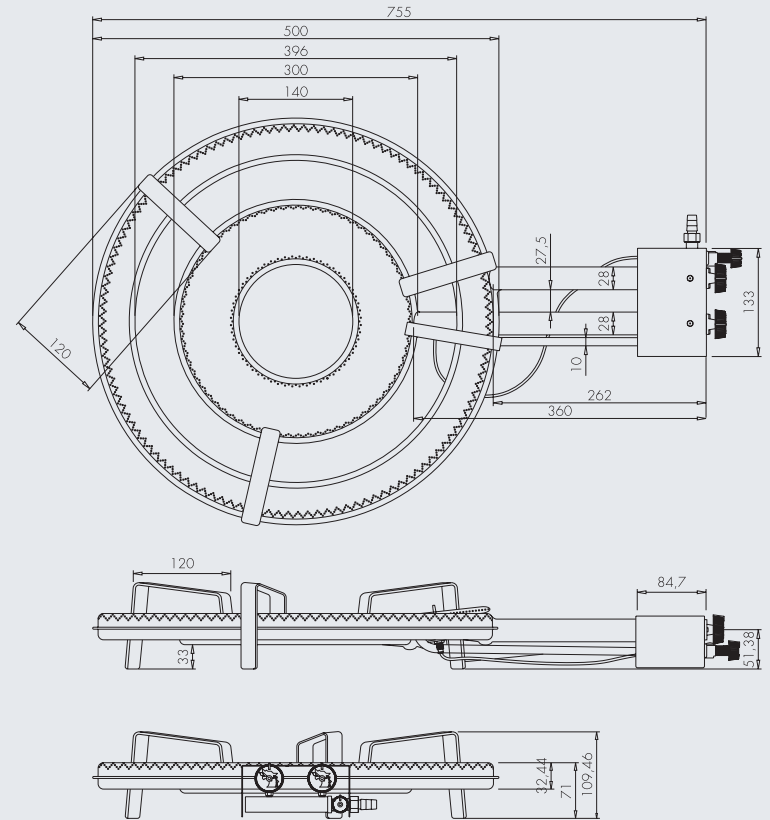

TT-600

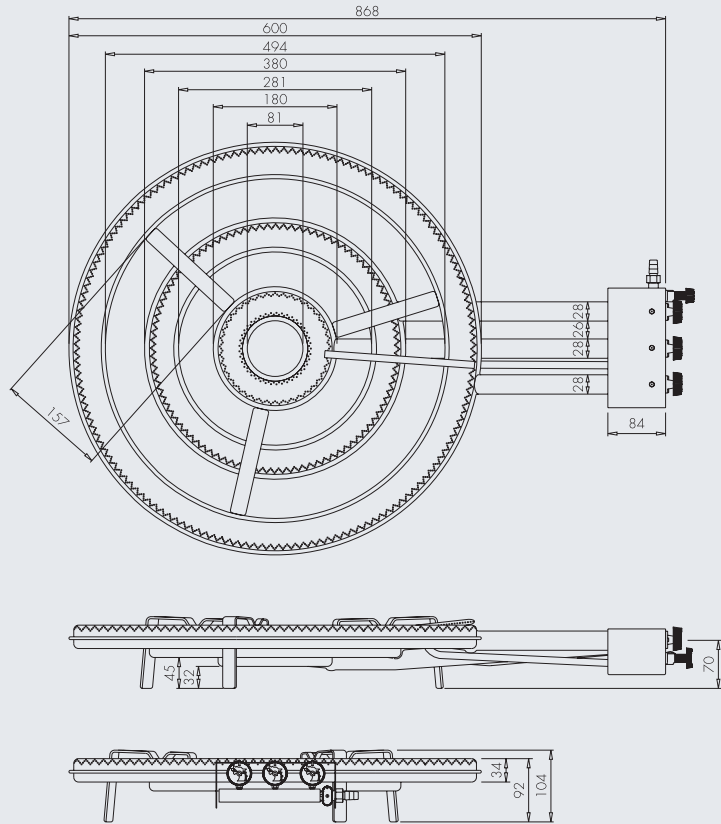

TT-700

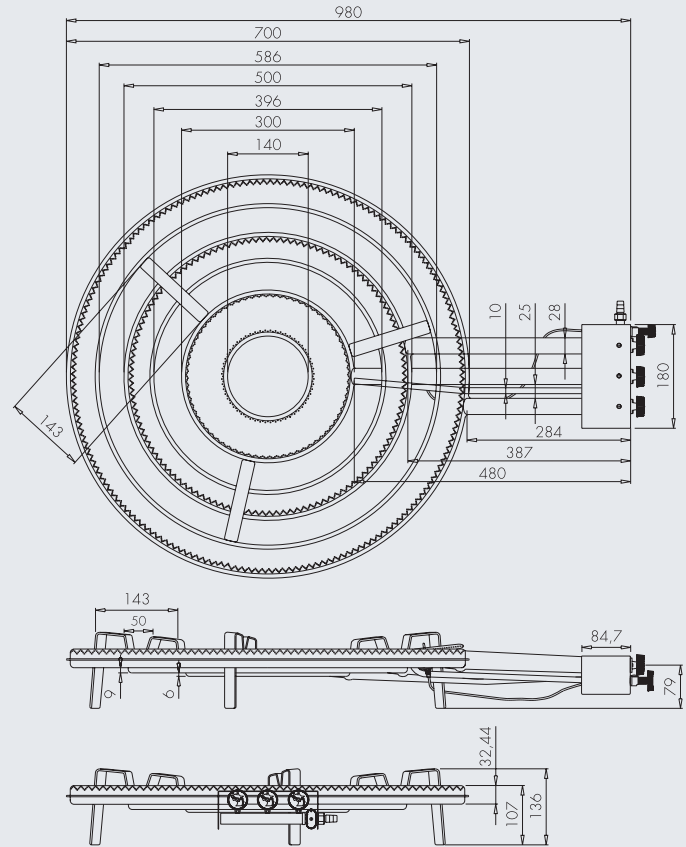

TT-900

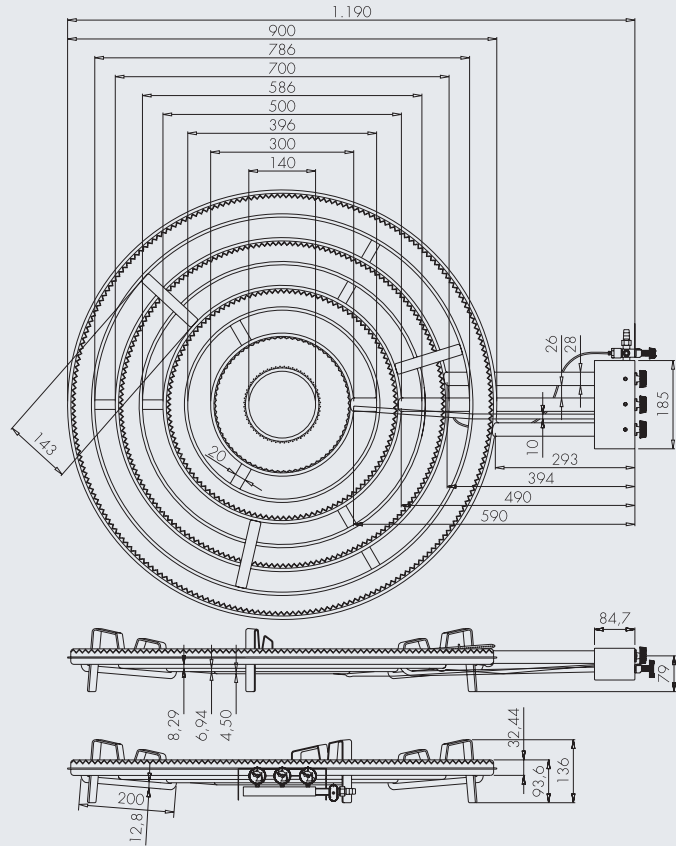

MAIN PARTS

M-400/16

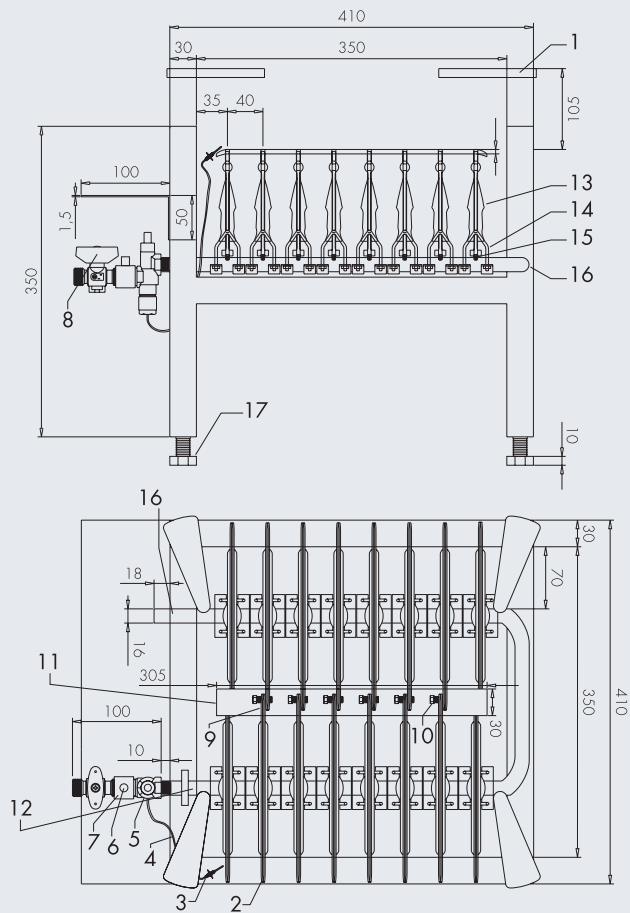

- 1- Support
- 2/13- Burner
- 3- Thermocouple
- 4- Thermocouple cable
- 5- Thermocouple valve
- 6- Pressure valve
- 7- Extension
- 8- Gas valve
- 9- Overlap
- 10- Sheet metal screw
- 11- Ignition element
- 12/16- Gas train
- 14- Clamp
- 15- Injector
- 17- Adjustable leg

MAIN PARTS

O-900/31 and O-1200/51

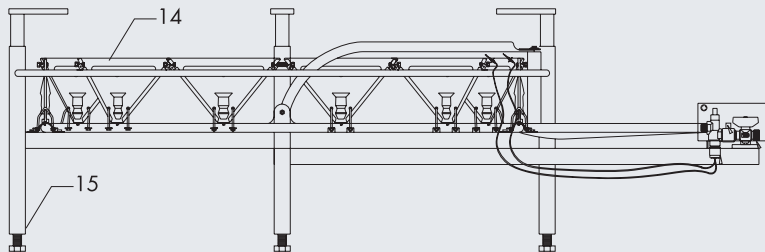
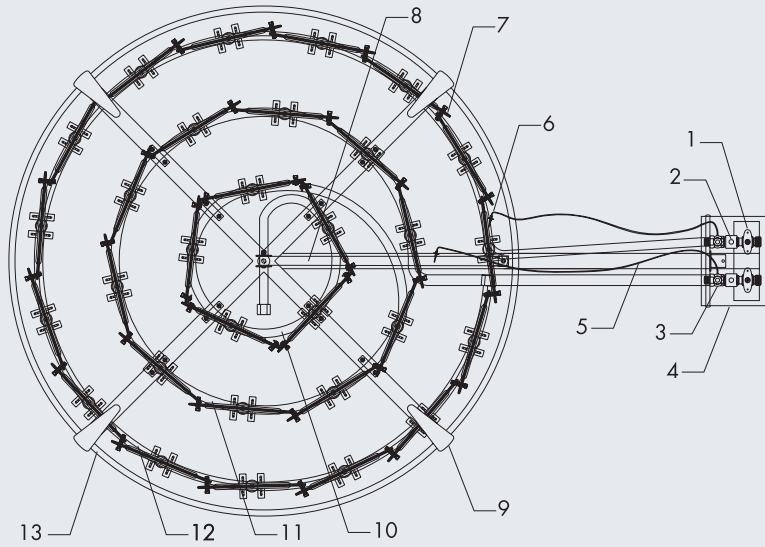

- 1- Gas valve
- 2- Gas pressure valve
- 3- Thermocouple valve
- 4- Valve cover
- 5- Thermocouple cable
- 6- Thermocouple sensor
- 7- Burner overlaps
- 8- Flame retardant pipe
- 9- Vessel support
- 10/11/12- Gas ring
- 13- Reinforcement ring
- 14- A-200 Burner
- 15- Adjustable leg

O-900/31

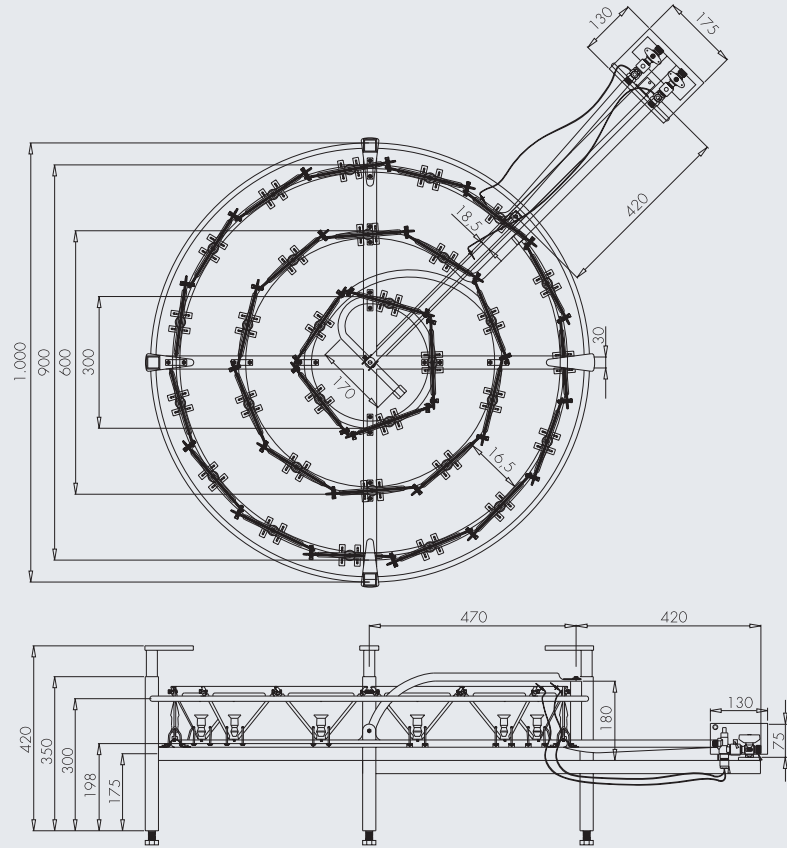

O-1200/51

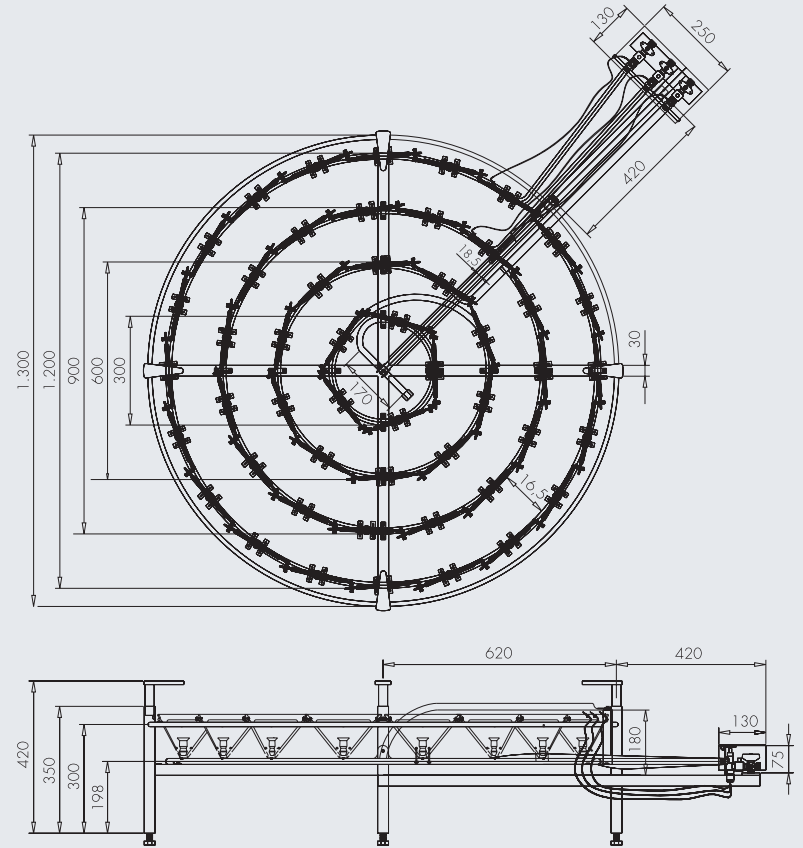

3 YEAR GUARANTEE CERTIFICATE

MODEL

DATE OF SALE

NAME AND ADDRESS OF PURCHASER

SELLER'S STAMP

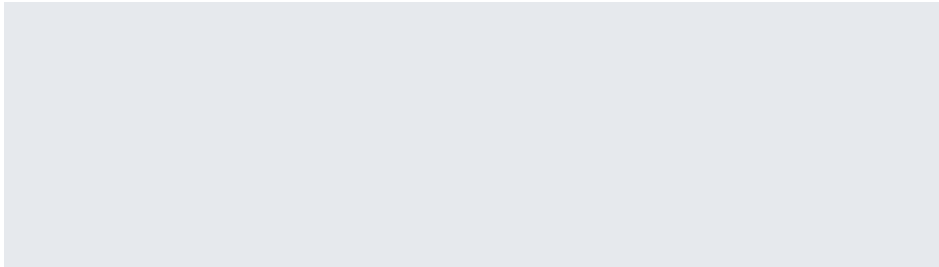

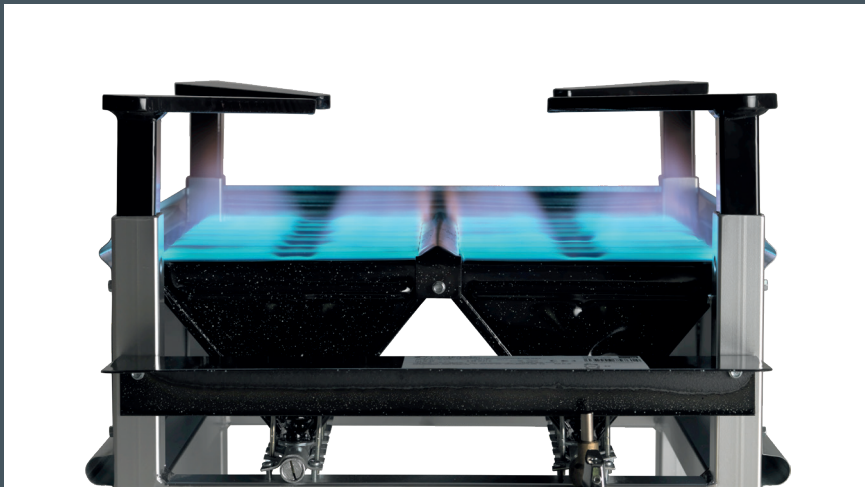

OPTIMGAS S.L. Pol. Industrial Sur, 29 - 46230 Alginet - Valencia, Spain
T. +34 961 753 556 / +34 961 751 304
info@flamesvlc.com - www.flamesvlc.com

